

Bennett Forgeworks

669 North Cora
Ridgway, CO 81432
Office 970-626-2100
Hours: Monday-Thursday 6:30a-5:30p, Closed Fridays.
forgeworksstainless.com

Lance Johnson

lance@forgework.com
Work Cell: 970-316-5850 (after office hours)

CUT SHEET (MEP)

Mechanical, Electrical, Plumbing, Ventilation

Date:	
Revision:	Original
Brewery:	
Location of Brewery:	
Brewhouse Size:	5 Barrel

Forgeworks can provide accurately scaled DXF files of shapes representing the equipment going into the brewery. An architect can then drop these into their model of the floor plan, and re-position as needed as you evaluate the arrangement of the equipment in the space.

Cut Sheet Sections

- 1) Equipment Descriptions, Power Requirements, Dimensions & Wet & Dry Weights
- 2) Brewhouse Footprint
- 3) Space Allowance for the Burner and Exhaust Components
- 4) Kettle Components/ UL Listings
- 5) Function and Production Flow of Equipment
- 6) Centrifugal Pump Performance Chart
- 7) Barley Cracker Information
- 8) Considerations for the layout of the Brewhouse
- 9) Burner Exhaust & Steam Venting Guidelines
- 10) Buyer's Responsibility Checklist

SECTION 1

Equipment Supplied		
Included Equipment	Component	Description
	<p>5bbl Kettle/Whirlpool Method of Heating Models:</p> <p>Model Options: (a) Electric (b) In-Direct Fire (c) Steam Jacketed</p> 	<p>Dimensions: 45.5" OD x 76" Tall Dry Weight: 675lbs Wet Weight: 2865lbs</p> <p>(a) Electric Kettles are heated via (4) Electric Immersion Elements that are inserted through 2" Ports, and connected by a 2" Tri-Clamp onto a ferrule. See Glo-Quartz Electric Immersion Element information below. Forgeworks does not supply the electric immersion elements for the electric heated Kettle.</p> <p>(b) An In-Direct fire Kettle is heated via a Natural Gas or Propane fueled Power Burner in a enclosed fire chamber. See the Midco Economite Burner Below.</p> <p>(c) Steam heated Kettles require a Steam Boiler (not provided by Forgeworks, and heat the Kettle via a jacketed layer around the walls and floor. The steam piping hookups are a 2" FNPT Inlet, and 1" FNPT Outlet.</p> <p>A simple controller is recommended to regulate the temperature. See the Johnson A421 information. In the case of an Electric Kettle, some varieties of Electric Immersion Elements each have their own built-in controller.</p>
	<p>Midco Economite Burner EC200 200,000 BTU</p>	<p>Controls the Kettle Burner (thermostat controller is a separate equipment; see Johnson A421 Controller. Note: may or may not be supplied by Forgeworks)</p> <p>Power Requirements: Gas Connection: 3/4" NPT</p>



Gas Pressure Required: 6-14" of Water Column. 10-14" w.c. is ideal
 Electrical Service: 120V / Single Phase / 60 Hertz
 Electrical Load: 3 Amps

For complete detail on installation/requirements see the manufacturers manual which can be emailed separately, found on our website on the Support Documents page under "Articles", or by visiting Midco International's website: www.midcointernational.com /

Electric Immersion Elements for Electric Kettle (4)

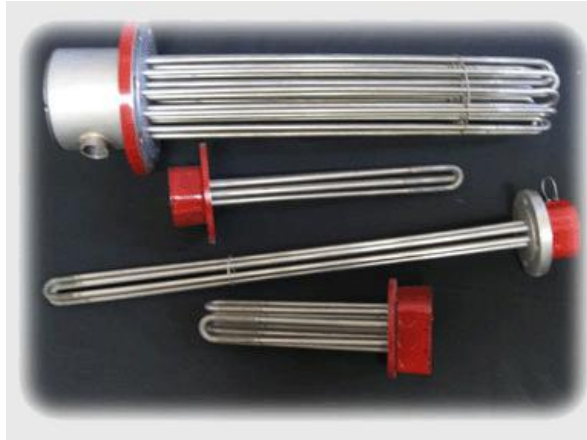

Controller

There are many manufacturers and suppliers of Electric Immersion Elements. This equipment is not provided by Forgeworks. We recommend you request quote from Glo-Quartz, a USA maker in Arizona. Contact Mike McGinnis at 800-423-4078 or email at: mmcginnis@gloquartz.com. <https://www.gloquartz.com/>

Power Requirements: 5bbl Electric Kettle
 50 kw, (4-heaters at 12,50kw ea) (to heat up to 200 gallons of wort, from 150°F to 212°F in 40 minutes). Service Requirements: 240V, 3-Phase, 121 Amps

Glo-Quartz Model #: D2SB-125EE38-E21B
 Flange Heater, 2" SANI 316 Stainless Steel Flange, 316 SS Elements, 38" Immersion, NEMA 4 Terminal Box, 60-250 F Pilot Duty Stat

Tank Light
 Archon LUM17LED

Added Equipment on the Kettle attached via a 2" Tri-Clamp Ferrule
Power Requirements:
 AC Supply (120/220-240/277) VAC
 12.6 Watts Power Consumption



5bbl Mash/Lauter Tun

Model Options:

- (a) Unheated
- (b) Steam Jacketed for Heating

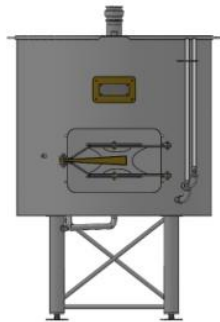

Dimensions:
 45.5" OD
 76" Tall w/ Flat Lid
 Dry Weight: 750lbs
 Wet Weight: 3027lbs

-If the Mash/Lauter Tun is equipped with jacketing for steam heat, the steam piping hookups are a 2" FNPT Inlet, and 1" FNPT Outlet.

5bbl Combi-Tank

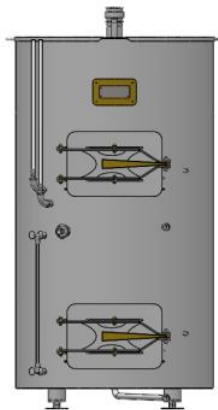

A Combi-Tank is a Hot Liquor Tank and a Mash/Lauter Tun stacked together. The Mash/Lauter Tun is on top of the HLT.

Dimensions:
 45.5" OD
 102.25" Tall w/Flat Lid
 Dry Weight:
 Wet Weight:

Electric Immersion Elements for the Hot Liquor Tank (Lower Tank of the Combi Tank)

Note: Electric Immersion Elements are not supplied by Forgeworks.
 We recommend the Glo-Quartz product;
<https://www.gloquartz.com/>
 Depending on the operator's brewing strategy, additional electric immersion element ports may have been added in addition to the (1) port that is standard. See below to see if this has been included.



Quantity of Electric Immersion Elements: 1

Power Requirements

Guideline:



Element Rated to 5298 Watts to raise temp 5° in 1/2 Hour, 2.648790984 kW Required

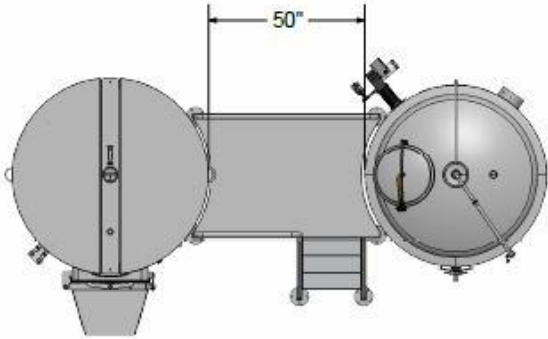

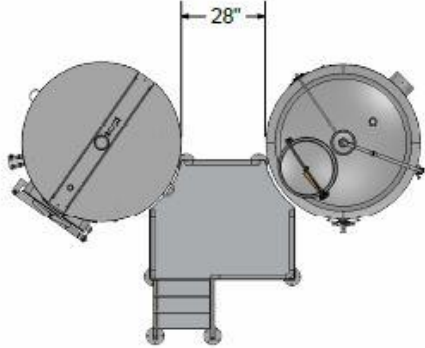
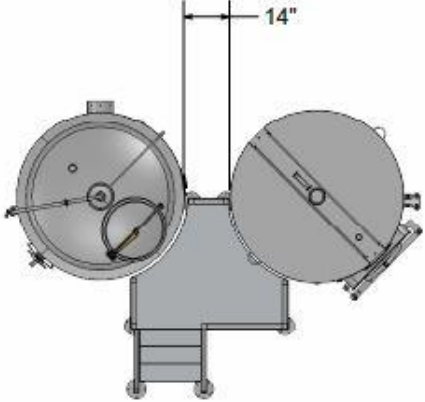
Thermostat Controller detailed separately, see Johnson A421 Controller. Equipment may or may not be supplied by

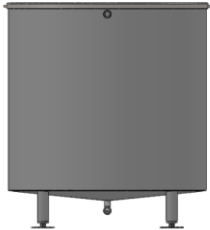
	<p>Please see detail at the bottom of section 1 concerning strategies for producing hot water (Hot Liquor) for the brewing process.</p>	<p>Forgeworks.</p>
<p>Rake and Plow Motor & VFD</p>		<p>Added Equipment for MashTun Power Requirements: MOVITRAC LTE-B+ VFD Unit - 230 V for 3-phase 230V Gearmotor – Input Current: 20.7 Amps SEW-Eurodrive Gearmotor: 230 V / 8.4 Amps or 460 V / 4.20 Amps</p>
<p>Tank Light Archon LUM17LED</p>		<p>Added Equipment for Mash Tun attached via a 2" Tri-Clamp Ferrule Power Requirements: AC Supply (120/220-240/277) VAC 12.6 Watts Power Consumption</p>
<p>Brewhouse Platform-Standard</p>		<p>Dimensions: Our standard platform. Spacious shelf underneath deck. 50" Between Tanks, 64" Deep, 36.5" from floor to the working deck, 78.5" from floor to top of railings, Weight: 390lbs</p>
<p>Brewhouse Platform;Narrow-Forward Option</p>		<p>A more compressed design than our standard deck, but wider and less forward than our Bikini version</p> <p>Dimensions: 28" Between Tanks, 36" width</p>

		<p>at the front, 40" Deep, 36.5" from floor to working deck, 78.5" to top of railings. Weight: 300lbs</p>
	<p>Brewhouse Platform; Bikini Option</p> 	<p>Our most compressed deck option that reduces the Brewhouse Footprint, and is a more <i>platform forward</i> design.</p> <p>Dimensions: 14" Between tanks, 48" width at the front, 40" deep, 36.5" from the floor to the working deck, 78.5" to the top of the railings. Weight: 300lbs</p>
	<p>5bbl Hot Liquor Tank (Hot Water) w/Electric Immersion Element Port for Heating</p> <p>Note: Electric Immersion Elements are not supplied by Forgeworks. We recommend the Glo-Quartz product; https://www.gloquartz.com/ Depending on the operator's brewing strategy, additional electric immersion element ports may have been added in addition to the (1) port that is standard. See below to see if this has been included.</p> <p>Please see detail at the bottom of section 1 concerning strategies for producing hot water (Hot Liquor) for the brewing process.</p>	<p>Dimensions: 51.5" OD 74" Height Dry Weight: Wet Weight: Quantity of Electric Immersion Elements: 1</p> <p>Power Requirements Guideline: Element Rated to 3784 Watts to raise temp 5° in 1/2 Hour, 1.89199356 kW Required</p> <p>Thermostat Controller detailed separately, see Johnson A421 Controller. Equipment may or may not be supplied by Forgeworks.</p>

		
	Add Additional Electric Immersion Element Port(s) in Hot Liquor Tank	Additional 2" Ports Added for increased heating ability of the Hot Liquor Tank.
	5bbl Hot Liquor Tank with Steam Jacketing for Heating	<p>Dimensions: 43.5" OD 76" Height Dry Weight: Wet Weight</p> <p>-The steam piping hookups are a 2" FNPT Inlet, and 1" FNPT Outlet.</p>
	<p>10bbl Hot Liquor Tank (Hot Water) w/Electric Immersion Element Port for Heating</p> <p>Note: Electric Immersion Elements are not supplied by Forgeworks. We recommend the Glo-Quartz product; https://www.gloquartz.com/ Depending on the operator's brewing strategy, additional electric immersion element ports may have been added in addition to the (1) port that is standard. See below to see if this has been included.</p> <p>Please see detail at the bottom of section 1 concerning strategies for producing hot water (Hot Liquor) for the brewing process.</p> 	<p>Dimensions: 45.0" OD 74" Height Dry Weight: 620lbs Wet Weight: 3301lbs Quantity of Electric Immersion Elements: 1</p> <p>Power Requirements Guideline: Element Rated to 7568 Watts to raise temp 5° in 1/2 Hour, 3.78398712 kW Required</p> <p>Thermostat Controller detailed separately, see Johnson A421 Controller. Equipment may or may not be supplied by Forgeworks.</p>
	Add Additional Electric Immersion Element Port(s) in Hot Liquor Tank	Additional 2" Ports Added for increased heating ability of the Hot Liquor Tank.
	10bbl Hot Liquor Tank with Steam Jacketing for Heating	<p>Dimensions: 58.5" OD</p>

		<p>80" Height Dry Weight: 775lbs Wet Weight 3456lbs</p> <p>-The steam piping hookups are a 2" FNPT Inlet, and 1" FNPT Outlet.</p>
	<p>5bbl Jacketed Fermenter</p> 	<p>Dimensions: 39-3/8" OD 88-37/64" Height Dry Weight: 490lbs Wet Weight: 1730lbs</p> <p>42L / 11.09Gal Jacketing Volume</p> <p>Thermostat Controller detailed separately, see Johnson A421 Controller. Equipment may or may not be supplied by Forgeworks.</p>
	<p>10bbl Jacketed Fermenter</p> 	<p>Dimensions: 47-1/2" OD 104-21/64" Height Dry Weight: 1400lbs Wet Weight: 5103lbs</p> <p>60L / 15.85Gal Jacketing Capacity</p> <p>Thermostat Controller detailed separately, see Johnson A421 Controller. Equipment may or may not be supplied by Forgeworks.</p>
	<p>5bbl Jacketed Bright</p> 	<p>Dimensions: 35-7/16" OD 72-53/64" Height Dry Weight: 540lbs Wet Weight: 1780lbs</p> <p>42L / 11.09 Gal Jacketing Volume</p> <p>Thermostat Controller detailed separately, see Johnson A421 Controller. Equipment may or may not be supplied by Forgeworks.</p>
	<p>10 bbl Jacketed Bright</p>	<p>Dimensions: 47-1/2" OD 86-39/64" Height Dry Weight: 1075lbs Wet Weight: 3887lbs</p> <p>60L / 15.85 Gal Jacketing</p>

		<p>Capacity</p> <p>Thermostat Controller detailed separately, see Johnson A421 Controller. Equipment may or may not be supplied by Forgeworks.</p>
	<p>Barley Cracker 1200</p>  	<p>Dimensions: 30"Long x 25" Wide x 37" High Weight: 225lbs Power Requirements: 1 HP Baldor L5023A Explosion Proof Motor, 60HZ, Volts 115/230, AMPS 13/6.5 RPM 1725, PH1/Class B 13Amp@110, 6.5Amp @230, pulls approx. 9.5 under full load Single Phase 110, can be wired to 220 12' of Wire is included, ready for your electrician to configure to the motor and your explosion proof connection box/switch.</p> <p>Grist Conveyance System: Flex Auger for Grist Conveyance (not supplied by Forgeworks but commonly paired with the Barley Cracker 1200). Farmer Boy Ag Model 350, ¾ HP Auger Motor pulls 4.6 Amps, 1 HP Auger pulls 6.2amps</p>



Single Phase Portable Centrifugal Pump



3-Phase Portable Centrifugal Pump

Power Requirements:

SP-41 Pump w/ Baldor 1.5hp with VFD. Single Phase input via VFD, three phase output to Motor. 10 Amps max. Plugs into standard electrical outlet, three prong plug.

Specs & Flow Capacity:

Washdown Motor
 3.75" Impeller
 3500RPM
 Maximum Efficiency: 50GPM
 Maximum Flow: 80GPM at 50' of Head

Power Requirements:

SP-41 Pump w/ Baldor 1.5hp with VFD, Three Phase, 5 Amps max

Specs & Flow Capacity:

Washdown Motor
 3.75" Impeller
 3500RPM
 Maximum Efficiency: 50GPM
 Maximum Flow: 80GPM at 50' of Head



3-Phase Fixed Mounted Centrifugal Pump
(on Brewer's Platform)

NOTE: These Pumps are fixed mounted, located on the bottom shelf of the platform.,



Power Requirements:

SP-41 Pump w/ Baldor 1.5hp with VFD, Three Phase, 5 Amps max

Specs & Flow Capacity:

Washdown Motor
3.75" Impeller
3500RPM
Maximum Efficiency: 50GPM
Maximum Flow: 80GPM at 50' of Head

Johnson A421 Controller

Thermostat Controller Equipment may or may not be supplied by Forgeworks.



(1) Controller each may be utilized for the Kettle/Whirlpool Burner, Hot Liquor Tank In-Direct Fire Burner or Electric Immersion Elements, Jacketed Fermenters & Jacketed Brights

Power Requirements:

Supply Voltage 120 VAC, 60 Hz
Power Consumption 1.8 Amps Max

Product Specifications:

Setpoint Range -30 to 212 F (-34 to 100 C)
Differential Range 1 to 30 F (1 to 30 C)

Brewer's Multi-Tool (4-Functions for the Brewery)

- Grant
- Hop Back
- Remote CIP (*may require power for heater*)
- Keg Cleaner (*requires access to CO2*)



The only function (of the four functions) of this equipment that may require power is the "Remote CIP Function" In this case an Electric Immersion Element is a component that can be installed to maintain temperature of the Clean-in-Place chemical solutions. The element would need to be wired and would plug into an appropriate wall plug. The location of the wall plug would best be located central to all the Stainless Steel tanks, as this equipment will be rolled around in proximity to each tank to run the Clean-in-Place process. The element will require a long enough extension cord (12AWG) to reach tanks (much like a vacuum cleaner).

NOTE: For the Keg Cleaning Function, access to a CO2 hose at the place where this equipment will be stationed during keg cleaning will be required. This unit is mounted to casters, thus can be easily moved around the brewery to perform its various functions.

Electric Immersion Element

There are many manufacturers and suppliers of Electric Immersion Elements. This equipment is not provided by Forgeworks. We recommend you request quote from Glo-Quartz, a USA maker in Arizona. Contact Mike McGinnis at 800-423-4078 or email at: mmcginnis@gloquartz.com. <https://www.gloquartz.com/>

Power Requirements:

Glo-Quartz Heating Element
Model # D2SB-35DD13-E2T1B
Description: 2" sani flange heater, 316 ss elements, 3.5 kw, 240 v, single ph, 13" immersion, nema 4 j-box, 60-250F SPST stat



Have a licensed/professional electrician wire the Electric Immersion Heating Element with a long extension cord (such as Southwire Royal X/C 12 AWG SOOW E46194 NC 600V, or equivalent) , and similar plug, using electrical components appropriate for the power requirements detailed above.

CITY WATER

It is recommended to have 60psi at 25-30 gallons per minute. Typically the Brew Kettle/Whirlpool is filled with treated or non-treated city water, via a standard hose bib and hose, and heated the afternoon before the scheduled brew day. In the morning. Depending on water quality, a filtration system may be implemented. On Brew Day, the hot water (Hot Liquor) is transferred completely or partially to the Hot Liquor Tank.

A hose bib station with both hot and cold water is needed in the brewing area. Kegging or Keg cleaning areas will also require tap water access.

NATURAL GAS / PROPANE

For Natural Gas fired Kettles or Hot Liquor Tanks, it is recommended to have 12-14" Water Column of Natural Gas for optimum performance of the in-direct fire natural gas burner. The manufacturer, Midco International, specs a Water Column range of 6-12. The Midco Economite burners we supply come set up for Natural Gas, but include a propane conversion kit. The Gas Connection to the Midco Economite Burner is 3/4" NPT.

NOTE: For more detailed information on individual components/support equipment, the manufacturers equipment manuals can be found on the Forgeworks website.

Go to:

<https://www.forgeworksstainless.com/articles/2018/4/18/support-documents>

Equipment Required for Brewery Production Operations, but not supplied by Forgeworks may include but not limited to:

- Cold Room (Refrigerated room for storage of yeast, single wall bright/serving tanks & kegs)
- Keg Cleaner Station
- CO2 System
- Water Treatment/Filtration System (if required)
- Hot Water on Demand System (if chosen to utilize)
- Electric Immersion Elements (if required for Hot Liquor Tanks or Electric Fired Kettles). We recommend Glo-

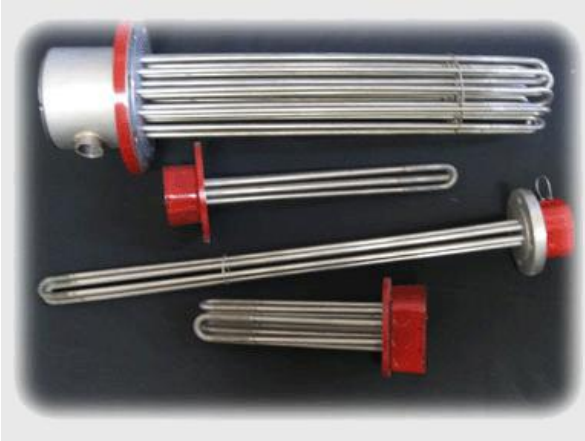

-Grist Conveyance System (if utilization of this equipment is elected). If our Barley Cracker 1200 is purchased, a flex auger from Farmer Boy Ag, Model 350 is an excellent choice if the path of travel is not excessively lengthy and not have horizontal turns. The power requirements of this equipment is listed together with the Barley Cracker 1200 power requirements detail above in Section 1.

-Glycol Chiller for Cellaring Equipment (Fermenters & Brights)

-Boiler for a Steam Jacketed Kettle, Hot Liquor Tank or Mash Tun (if applicable)

Heat Exchanger (aka Wort Chiller):

-Heat Exchangers do not require power for their operation. This equipment may or may not have been purchased from Forgeworks. Heat Exchangers are portable, and can be equipped with casters to relocate when not in operation. The heat exchanger is often positioned in a fixed location, and requires a footprint of approximately 11" width, and 25" Length. The Heat Exchanger's function is to rapidly cool the hot wort during its transfer (called Knock-Out) from the Kettle to the Fermenter. The target temperature of the wort at entry into the fermenter is 68° for Ales and 50° for Lagers. The hot wort is cooled in the exchanger by the city tap water in a Single Stage Exchanger. If the city tap temperature is not cool enough to generate the target temperature, a 2-Stage Exchanger is required, and the second stage of cooling is accomplished with either Cold Liquor (water cooled in a glycol jacketed tank, or water cooled in single walled vessel in a cold room) or by glycol routed from the glycol chiller. The following are sample specifications based on producing Ales on a 5bbl system, with a 30-Minute Knock-Out, with 70° tap water, with a second stage cooling agent at 40° (Glycol or Cold Liquor).



Knockout time	30 minutes			
Duty Specifications				
	Stage 1		Stage 2	
	Hot side	Cold side	Hot side	Cold side
Fluid	<i>Beer-wort</i>	<i>Water</i>	<i>Beer-wort</i>	<i>Cold Liquor</i>
Flow rate	5.1 GPM	6.6 GPM	5.1 GPM	1.8 GPM
Temperature in	212°F	70°F	77°F	40°F
Temperature out	77°F	176°F	68°F	66°F
Pressure loss	2.91 PSI	4.08 PSI	3.27 PSI	0.45 PSI
Plates	51		5	
BTUs exchanged	346000		23500	

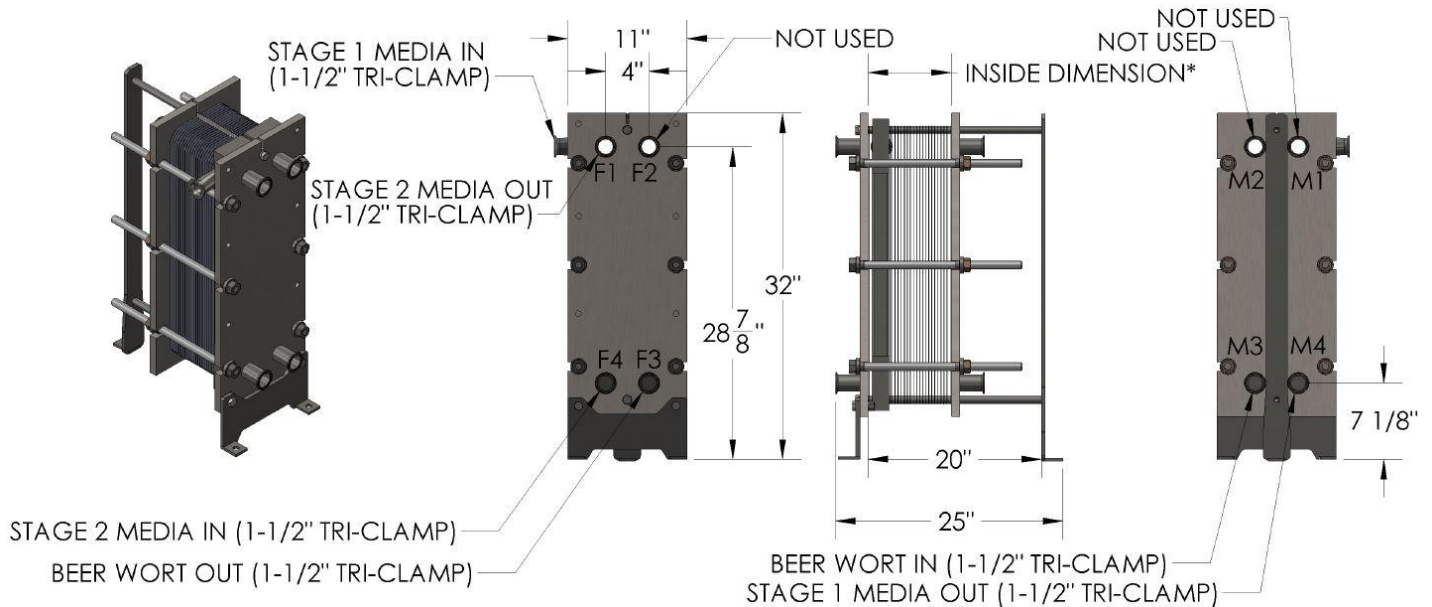

Producing Hot Liquor (Hot Water) for the Brewing Process

An In-Direct Fire Brewhouse from Forgeworks is typically used in the following way for the production of hot water for the brewing process. This is in conjunction with a Hot Liquor Tank with ports for (1) or multiple electric immersion elements.

-The Hot Liquor is heated in the In-Direct Fire Kettle/Whirlpool the afternoon before the brew day. The temperature in the Kettle is maintained overnight. On the morning of the brew day. The hot liquor is either fully or partially transferred to the Hot Liquor Tank. If only partially transferred, the hot water is initially

transferred to the Mash Tun for Mash-In (Strike Water), and the balance of the hot water is transferred to the Hot Liquor Tank for Lautering, and other uses such as cleaning.

The Hot Liquor Tank equipped with 2" ports for (1) or more electric immersion elements is not intended to heat the brew water from tap temperature to the temperature to required to begin the brewing process in the Mash/Lauter Tun. The electric elements are utilized only to slightly raise the temperature....in the case of a significant delay in brewing, after the transfer of the hot water from the Kettle.

When figuring the power requirements for the Electric Immersion Element(s), consider the scenario described above. The wattage use found in the Hot Liquor Tank description is for the use of one element, to raise the temperature by 5° in 30 minutes.

The Electric Immersion Elements are not provided by Forgeworks. We do however recommend Glo-Quartz, a US Manufacturer of Electric Immersion Elements. Call Mike McGinnis at 800-423-4078, or email at mmcginnis@gloquartz.com. Or visit <https://www.gloquartz.com/>

For further power requirement information on Electric Immersion Elements, you can check out our Wattage Guidline Calculator on our website's support document page, under the Electric Immersion Element heading:

<https://www.forgeworksstainless.com/articles/2018/4/18/support-documents>

and reach out to Glo-Quartz.

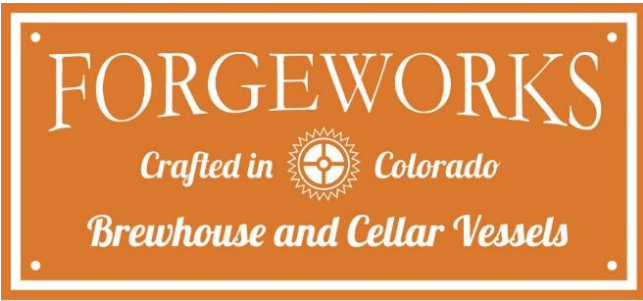

SECTION 2

Brewhouse Footprint

Note: If a Hot Liquor Tank is utilized, it is not included in the brewhouse footprint unless a custom 3-Vessel Platform is specified. The Brewhouse Footprint is made up of the Kettle/Whirlpool tank, the Mash/Lauter Tun, and the Platform. The Kettle/Whirlpool can be oriented on the left or right of the platform, depending on the flow dictated by the location, proximity to exit doors, etc. (in the case of hauling out spent grain bins). The Hot Liquor Tank can be located anywhere in the brewery. Typical locations include: 1) Next to the Kettle, 2) Behind the Platform, or 3) another location in the brewery that is not in the way of or occupied by other equipment, such as cellaring tanks. For dimensions of the Hot Liquor Tank (if purchased from forgeworks), see Section 1.

Footprint with Standard Platform

SHEET_FORMAT_VERSION: 20170823

5 BBL BREWHOUSE STANDARD FOOTPRINT

ALL DIMENSIONS, PORTS AND FEATURES ARE CUSTOMIZABLE.

TOP

ISO

FRONT

HOT LIQUOR TANK OPTIONS

	A - HEIGHT	B - DIAMETER
10 BBL HLT - FLAT LID	5' - 15"	4' - 4"
10 BBL HLT - DOME TOP	6' - 15"	4' - 4"

APPROVAL SIGNATURE	CURRENT REVIEWER: A	DATE	SERIAL NUMBER	VOLUME	PAGE 1 OF 1
CUSTOMER NAME / COMPANY	ADW / PART / WELDMENT DESCRIPTION: 5 BARREL BREWHOUSE AND HOT LIQUOR TANK, FLOOR LAYOUT MATERIAL: 304 STAINLESS				

WARNING: PROPRIETARY AND CONFIDENTIAL INFORMATION.
 This document and the information contained herein are the confidential and proprietary information of FORGEWORKS. Customarily obtained. This document is covered by Electronic Communications Privacy Act, 18 U.S.C. § 876(2)(C) and is intended only for use of person or entity to which it is addressed. If you are not the intended recipient or have received this message in error, you are prohibited from disseminating or otherwise using the information herein. Receipt of this document is acknowledged and acceptance that this is proprietary, confidential and not to be forwarded to any party without prior written consent from the sender.

Footprint with Narrow Forward Platform Option

SHEET FORMAT VERSION: 20170823



5 BBL BREWHOUSE WITH NARROW FORWARD PLATFORM

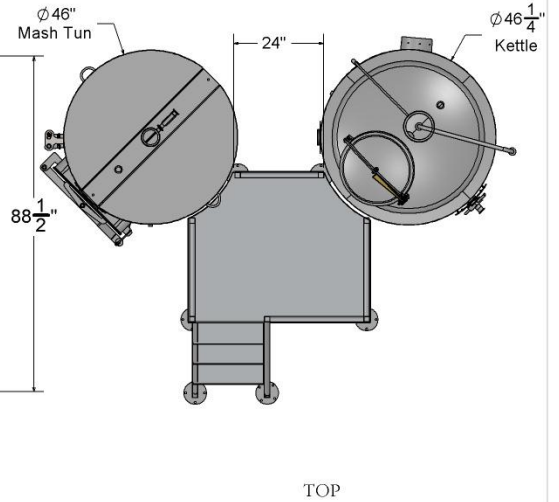
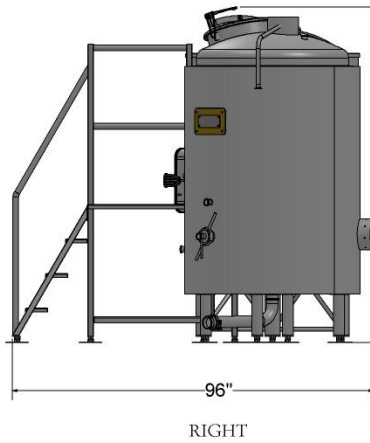
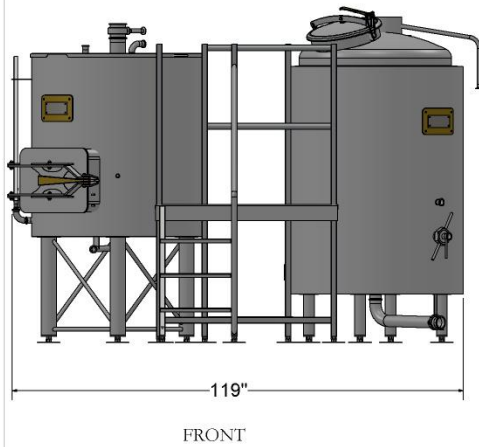

*ELEVATIONS AND PORT ARRANGEMENTS ARE CUSTOMIZABLE.

CURRENT REV/VER: X		SERIAL NUMBER	VOLUME	WEIGHT
REV/VER	DESCRIPTION	DATE	ASM / PART / WELDMENT DESCRIPTION	1627.75 LB
APPROVAL SIGNATURE		MATERIAL (or see note(s))		SHEET
CUSTOMER NAME / COMPANY		Material (not specified)		1 of 1

WARNING: PROPRIETARY AND CONFIDENTIAL INFORMATION.
This document and the information set forth herein are confidential and proprietary to BENNETT FORGEWORKS. Confidentiality statement: This document is covered by Electronic Confidentiality Policy, A.E. 10.1.1.1. It is intended only for use of person or entity to which it is addressed. If you are not the intended recipient or have received this message in error, you are prohibited from disseminating or otherwise using this information under law. Receipt of this document is acknowledgment and acceptance that this is protected, proprietary and confidential and will not be forwarded to any party(s) without your written consent from the sender.

Footprint with Space Saver Option B

SHEET FORMAT VERSION 20170823



5 BBL BREWHOUSE WITH SPACE SAVER PLATFORM

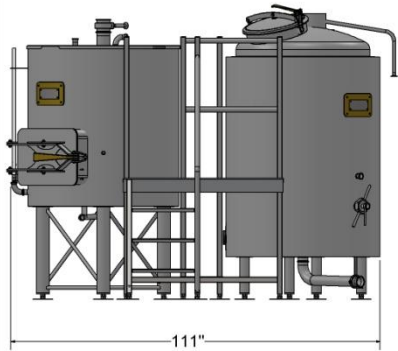

FRONT

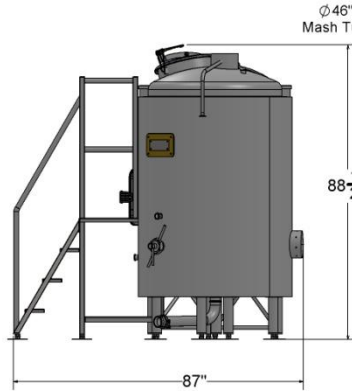

RIGHT

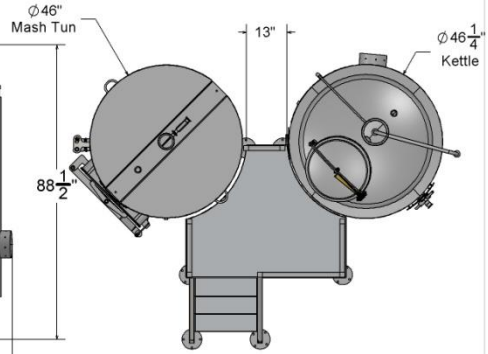

TOP

*ELEVATIONS AND PORT ARRANGEMENTS ARE CUSTOMIZABLE.

CURRENT REV/REV: X		SERIAL NUMBER	VOLUME	INSTRUMENT ID
REV/REV	DESCRIPTION	DATE	ASM / PART / BILLMENT DESCRIPTION	
APPROVAL SIGNATURE		MATERIAL IN THE ASM (S)		SHEET
CUSTOMER NAME / COMPANY		Material (not specified)		1 of 1

WARNING: PROPRIETARY AND CONFIDENTIAL INFORMATION.
 This document and the information contained herein are the property of FORGEWORKS. Confidential information. This document is covered by Electronic Communications Privacy Act, 18 U.S.C. (2510-2521) and is intended only for use of person or entity to which it is addressed. If you are not the intended recipient or have received this message in error, you are prohibited from disseminating or otherwise using the information within this document. If you are not the intended recipient, please notify the sender immediately. This document is a confidential and controlled document. All rights reserved. Property and confidential information will not be disseminated to any party without prior written consent from the sender.

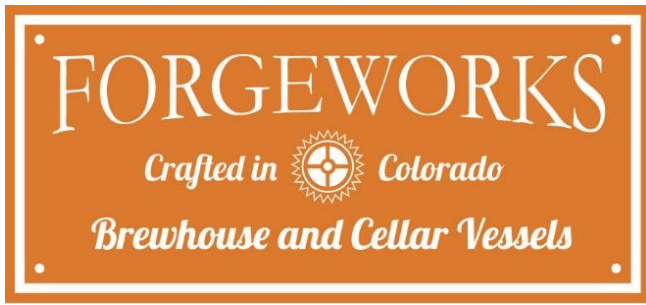

SECTION 3

Space Allowance for the Burner and Exhaust Components

In-Direct Fire Exhaust Venting

At a minimum, the venting from the In-Direct Fire Kettle or In-Direct Fire Hot Liquor Tank shall be comprised of insulated, Stainless Steel lined, Stainless Steel Outer, Class A chimney parts. A minimum of 2" of clearance must be maintained from walls and combustibles. Any needed wall supports or other supports by the manufacturer of your venting choice, provide at least 2" of clearance. The first two parts of the venting, the exhaust port adaptor and the Tee, will require 12" of width and 18.5" (for 3.5bbl-10bbl, and 16" by 20.5" for 15bbl) of length for appropriate clearance from walls and other obstacles (picture a 12" by 18.5", or 16" by 20.5" for 15bbl, rectangle jetting out from the kettle, on center from the location of the exhaust port).

Burner Installation:

For placement of the Kettle or Hot Liquor Tank in the brewery, allow adequate clearance for the burner, figure a 16" width x 20" length area. The burner mounts to the In-Direct Fire Kettle or In-Direct Fire Hot Liquor Tank via the burner's universal flange, married up to (4) .25" bolts that are fixed on the vessel around the 4.125" burner port. The .25" nuts are supplied, and come threaded on the bolts over a washer.

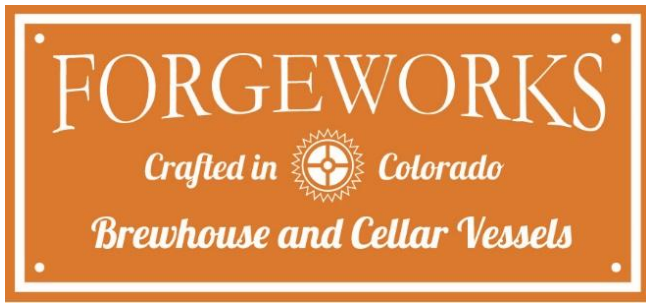

SECTION 4

Components for Kettle or other Vessels

Gas Burner System on Kettle

Forced Air Natural Gas Burner heats fire chamber on Kettle, Exhaust is vented out of the building, via 8" Class A Double-Walled Stainless steel Chimney parts with an in-line Draft Control.

Midco International Economite EC 200 or 300 Power Gas Burner

This Burner is to be mounted to the bolts around the Kettle Burner Port via the Midco Factory provided flange.

[Product Information Link](#)

[Wiring Diagram Link](#)

UL listed/approved, file/certificate report number MH27899, volume 1, section 2, tested to ANSI Z21.17-1998 product standard

Gas Connection: ¾" NPT

Gas Pressure Range Required: 6.0-14" WC

Install In-Line Pressure Regulator prior to burner, [Maxitrol](#) Products are reputable

Electrical Service: 120V / Single Phase / 60 Hertz

Electrical Load: 3 Amps

300 MBH consumption rate (90 MBH min to 300 MBH maximum firing rate)

Fenwall Controller 35-60 & 35-61

Installed on the Midco EC 200 or 300 Burner

[Product Information Link](#)

[Wiring Diagram Link](#)

UL Component Recognized System

Designed Certified to UL 372, File MH8817

Software conforms to UL 1998 requirements

Pipe Size	Type of Gas	Approximate Capacity -MBH				
		Pipe Length				
		10	20	40	75	100
3/4	Natural	200	150			
3/4	Propane	590	400	275	190	160
1	Natural	400	275	200	150	
1	Propane	1075	730	500	360	300
1 1/4	Natural	900	600	450	325	275
1 1/4	Propane		1040	750	630	
1 1/2	Natural		900	650	475	400
1 1/2	Propane					975

Capacities shown are for a total pressure drop of 0.3" W.C. For 0.5" W.C. pressure drop, multiply capacity shown by 1.3. Propane capacities shown are for a total pressure drop of 0.5" W.C. For higher permissible pressure drops, consult your gas supplier.

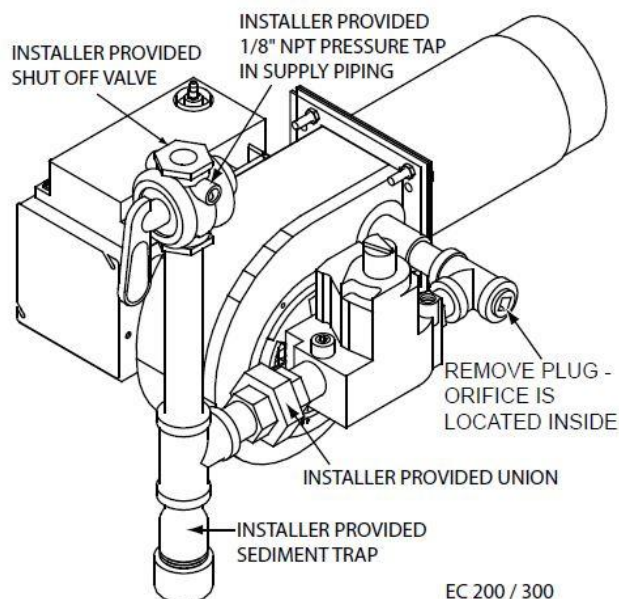

Johnson A421 Controller for Burner Temperature Control

Unit Mounted to a Wall or on the Kettle to control temperature in the kettle. Controller is wired to the Fenwall Controller that is attached to the Midco Burner. Along with this unit, your HVAC profession is to install a Cut Off Switch to the Johnson Controller to act as an Emergency Burner Cutoff, and ON/OFF Switch. (See Burner and Venting Guidelines provided)



[Product Information Link](#)

[Wiring Diagram Link](#)

Product Specifications

Setpoint Range -30 to 212 F (-34 to 100 C)
Differential Range 1 to 30 F (1 to 30 C)
Supply Voltage 120 VAC, 60 Hz
Power Consumption 1.8 Amps Max

Venting on Kettle (Steam and Exhaust)

**Kettle Steam Venting-Single Wall Stainless or Aluminum(ABSOLUTELY NO GALVANIZED):
8"ID**

**Kettle Exhaust for Indirect Fire (Gas Power Burner): Class A Double-Wall Stainless, Aluminum
or Galvanized 8"ID**

Suggested Exhaust Venting for Fire Chamber

Selkirk SuperVent JSC Class A Double-Wall Stainless Steel
UL 103-HT (8")

Suggested Draft Control for Exhaust Venting

Control installed after 1st Straight Section of Class A Chimney

Field Control Draft Control Type MG-1

UL Listed

Steam Venting: Utilize any quality commercial grade single wall Stainless Steel (8") Chimney Parts. A direct line through ceiling/roof is best, or with minimal turns no greater than 45°. In the case of venting through a wall to the outside, use a max of (2) 45° Elbows (one on the inside, one on the outside of the building) and the rest, straight sections. Galvanized material is not recommended because of its lack of durability with exposure to cleaning caustics and acids used in the Kettle. If the run is particularly long, and stainless or Aluminum is cost inhibitive, then have the first 2-3 sections be stainless or aluminum, and the rest galvanized.

Archon Industries Inc- Tank Light Model LUM17

Certificate # 20180301-E175164, Report Reference E175164-19970207

UL 1598 and CSA C22.2 No. 250 Standard for Luminaires, and UL 8750 Standard for Light Emitting Diode (LED).

Washdown Safe, IP65 rated per IEC 60529

Power Consumption: 12.6 Watts

AC Supply: (120/220-240/277) VAC

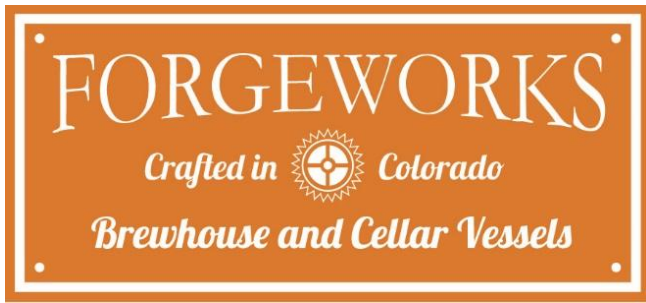

SECTION 5

Steam Fired Brewhouse, Kettle/Whirlpool, Mash/Lauter Tun, Hot Liquor Tank

A Boiler manufacturer will need to be selected by the customer, as Forgeworks does not supply this equipment. We do recommend the following credible Boiler manufacturers:

- Columbia Boilers
- Hurst Boilers
- Rite Boilers
- Allied Engineering Company

The Forgeworks Steam Fired Brewhouse consists of insulated tanks with Jacketing wrapped around the the outside of the inner wall which will house the in and out flow of steam that is routed from the Boiler.

A Local Licensed HVAC company that has expertise in pipe fitting for Boilers must supply, fabricate and install all the necessary piping for the inlet and outlet of each Steam Fired tank on the Brewhouse.

The specific model and capability of the Boiler must be recommended by the Boiler manufacturer of your choice, and is typically based on the volume of the steam jacket on each tank, and the necessary piping to make all tank connections from the boiler room.

Forgeworks will work with your selected Boiler manufacturer to provide the jacketing volume information. This will give them the information to determine how much horse power output the Boiler will need to provide.

Johnson A421 Controller for Burner Temperature Control

Unit Mounted to a Wall or on the Kettle to control temperature in the kettle. Controller is wired to the Fenwall Contoller that is attached to the Midco Burner. Along with this unit, your HVAC profession is to install a Cut Off Switch to the Johnson Controller to act as an Emergency Burner Cutoff, and ON/OFF Switch. (See Burner and Venting Guidelines provided)



[Product Information Link](#)
[Wiring Diagram Link](#)

cULus Listed; UL 60730, File E27734, Vol. 1; FCC Compliant to CFR47, Part 15, Subpart B, Class B

Product Specifications

Setpoint Range	-30 to 212 F (-34 to 100 C)
Differential Range	1 to 30 F (1 to 30 C)
Supply Voltage	120 VAC, 60 Hz
Power Consumption	1.8 Amps Max

Venting on Kettle and Hot Liquor Tank (Steam Vent)

Steam Venting-Single Wall Stainless or Aluminum(ABSOLUTELY NO GALVANIZED):

Steam Venting: Utilize any quality commercial grade single wall Stainless Steel (8") Chimney Parts. A direct line through ceiling/roof is best, or with minimal turns no greater than 45°. In the case of venting through a wall to the outside, use a max of (2) 45° Elbows (one on the inside, one on the outside of the building) and the rest, straight sections. Galvanized material is not recommended because of its lack of durability with exposure to cleaning caustics and acids used in the Kettle. If the run is particularly long, and stainless or Aluminum is cost inhibitive, then have the first 2-3 sections be stainless or aluminum, and the rest galvanized.

Archon Industries Inc- Tank Light Model LUM17

Certificate # 20180301-E175164, Report Reference E175164-19970207

UL 1598 and CSA C22.2 No. 250 Standard for Luminaires, and UL 8750 Standard for Light Emitting Diode (LED).

Washdown Safe, IP65 rated per IEC 60529

Power Consumption: 12.6 Watts

AC Supply: (120/220-240/277) VAC

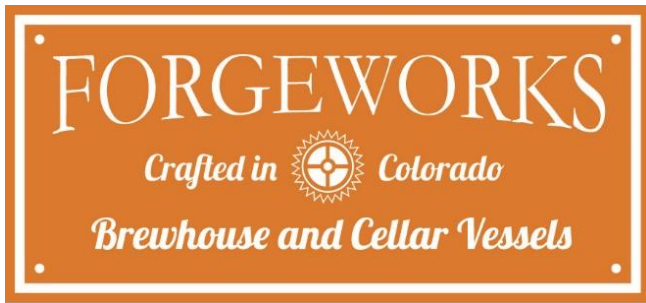

SECTION 6

FORGEWORKS BREWHOUSE VESSELS

FUNCTION AND PRODUCTION FLOW

In a modern brewery, the "brewhouse" is comprised of the vessels that process fluids at high temperatures, sometimes referred to as the 'hot side' of a brewery. Afterwards, the unfermented beer, or wort, is sent to the 'cold side' of the brewery for fermentation or conditioning.

Forgeworks primarily fabricates a two-vessel brewhouse system where each tank performs several functions of the brewing process.

There are four processes in the production flow of a typical brewhouse:

- **Mash** – Milled barley and adjunct grains, called grist, are combined with hot water (approx. 160 degrees) to produce an oatmeal-like solution called the mash
- **Lauter** – The sugar-rich liquid of mash (called wort) is separated from the grain in the mash by filtering the liquid through a metal screen. After filtration the wort is transferred to a boil kettle
- **Boil** – The wort is boiled usually for an hour, other ingredients like hops and herbs are added here
- **Whirlpool** – After the boil is finished the wort is recirculated in the boil kettle, creating a whirlpool effect which causes sediment to collect at the bottom of the tank

Large production breweries will often have a separate vessel for each of the four processes listed above. A Forgeworks brewhouse saves space and cost by combining processes into a **Mash/Lauter Vessel**, referred to as a Mash Tun, and a **Boil/Whirlpool Vessel**, referred to as a Kettle.

Key components of the Mash Tun

- The mash tun is equipped with a manway at the bottom of the tank to provide access for cleaning and disposal of the hundreds of pounds of spent grain
- A v-wire screen to filter the wort from the spent grain
- A thermowell port to monitor temperatures
- A drain to transfer fluid to the kettle for the boil
- The mash tun has no heating elements, burners or electronic equipment

Key components of the Kettle

Kettle components are to be installed by a licensed HVAC professional/Electrician. Components may have

been provided by Forgeworks, but not manufactured by Forgeworks. Some components required will need to be sourced by a licensed HVAC professional/Electrician.

- Heated by an indirect fire burner system or multiple electrical immersion heaters. Indirect fire systems utilize a Natural Gas Power Burner which blows a flame into a closed firing chamber
- Exhaust venting flange used to attach Class A Chimney parts, to route burner exhaust to the outside of the building
 - Exhaust venting, not provided by Forgeworks but required upon installation, is required of 8" Double Wall Class A Stainless Steel Chimney sections, with an inline draft controller
- Steam venting which vents steam produced during boiling. A Steam collar is attached to the dome lid of the kettle, and is to be married up with 8" Single Wall Stainless Steel chimney parts (not manufactured or supplied by Forgeworks)
- A Johnson A421 Temperature Controller to monitor and control the temperature of the liquid in the kettle (not manufactured by Forgeworks, but may have been included as part of a brewhouse package)
- An Emergency cut off switch within reasonable reach of the brewer during kettle operation (not manufactured or provided by, but recommended upon installation)
- Each Kettle is equipped with a 2" port on the dome lid that can be used to install a Foam Sensor switch to prevent an accidental boil-over. The Foam Sensor is to be purchased separately by the customer, should they want to install such safety equipment.

The Kettle is never subjected to internal pressure under normal working conditions. The steam produced during the boil is vented through an 8" Chimney at the top of the kettle, and is directed out of the building, separate from the fire chamber exhaust venting. If a Steam Stack Slide Gate was purchased as an accessory option for the kettle, use of this gate will not create an internal pressure condition, as the slide gate is not airtight. The kettle is not designed to be a pressure vessel, and it does not require pressure to operate.

Cold Side of the Brewery – Fermentation and Conditioning

After the Whirlpool process, the hot wort is transferred through a plate heat exchanger where it is cooled to between 50 and 70 degrees prior to fermentation. Forgeworks does not manufacture these heat exchangers but will often source these units for customers if they request. Once the wort is fully transferred into the Fermenter, the fermentation process begins, often referred to as the "Cold Side" of the brewing process.

Fermentation vessels, or fermenters, utilize a dimpled cooling jacket which refrigerates the beer by using a glycol chilling system (not manufactured or sourced by Forgeworks).

After the fermentation process, beer is transferred to a Bright Tank for conditioning, and may be directly connected to a draught system for serving in a tap room.

Fermentation and Bright Tanks are referred to as Cellaring Equipment, and this equipment may have or may not have been provided by Forgeworks.

All transfers of wort or fermented beer from one vessel to the other are performed by centrifugal pumps, which are not manufactured by Forgeworks but are sometimes sourced as a part of a brewhouse package.

Direct any questions or requests for clarification to:

Will Brumas
Mechanical Engineer
970-626-2100
will@forgework.com

or

Lance Johnson

Technical Sales/Marketing

970-613-5850

lance@forgework.com



SECTION 7

Centrifugal Pump Performance

SP-41, 1.5HP

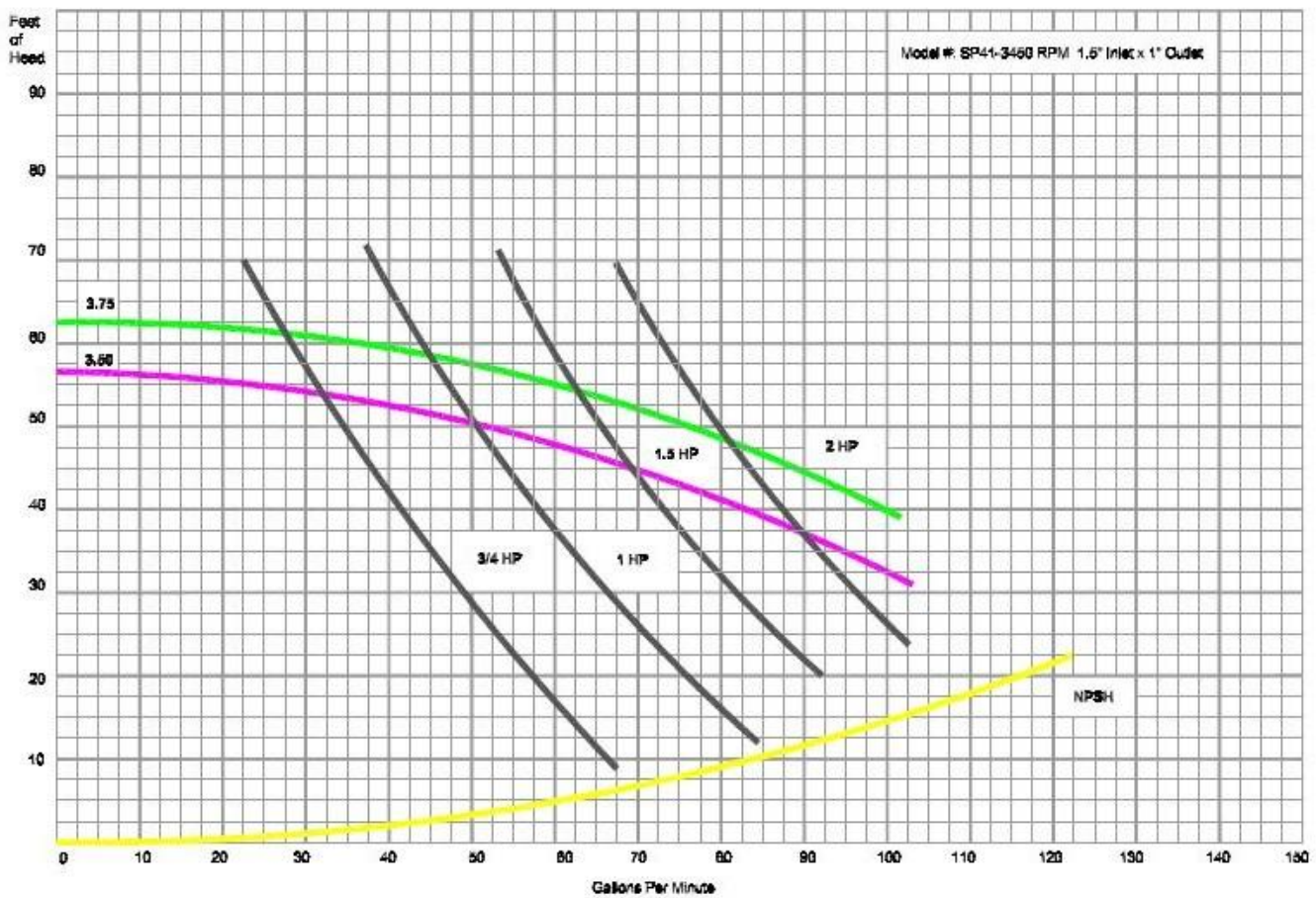

Pump Performance Curves

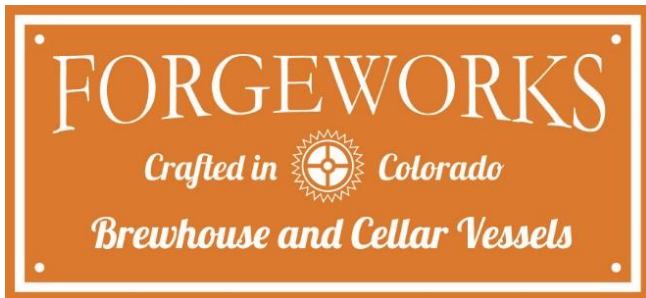

SECTION 8

To: City Inspectors, Governing Agencies, Fire Marshalls **RE: Barley Cracking Equipment**

The Forgeworks Barley Cracker 1200 features a lid which creates a barrier to eliminate grain dust from escaping the hopper, and is intended to be used during the operation of the Barley Cracker, as well as during non use times. Another feature of The Barley Cracker is that it is equipped to utilize an flex auger type conveyance system to move the cracked barley via a closed system to the Mash Tun, and through a grist hydration apparatus. The auger connections, both at the Barley Cracker's output, and at the discharge end at the Mash Tun via the Grist Hydrator (see pictures below) provide a closed system to safeguard against the accumulation of dust or dust clouds. For additional safety, the motor on the equipment is a Baldor L35023A Explosion Proof motor. You can find information on this motor, and other information pertaining to the Barley Cracker on our website, in the "Articles" section.

<https://www.forgeworksstainless.com/articles/2018/4/18/support-documents>

The Barley Cracker is engineered to crack 85% of the grain greater than 600 Microns, with 10% being a particle size between 250 and 400 microns, and 5% less than 250 microns. All particle sizes generated are safely contained, and combined to produce a trouble free mash with maximized extraction efficiencies. With correct installation of the equipment performed, the produced crush/grist is delivered to the Mash Tun with minimal to zero levels of escaping dust. With best practices of a good periodic brewery cleaning of all surfaces, adequate ventilation, combined with the use of the barrier lid and closed conveyance connections on your grain cracking operation, your brewing environment will be kept safe from settling dust, and presence of grain dust clouds in the air. The electrical connection of the equipment to a outlet is specified to be a hard wired sealed explosion proof connection with a switch.

With all these features and practices in place, the Forgeworks Barley Cracker virtually eliminates any deflagration (rapid combustion) risk introduced by accumulated dust or dust clouds resulting from the use of the equipment.

Nearly all of our Barley Crusher customers utilize this equipment without the need or requirement of an a separate enclosed room, or fire suppression systems, as a pre-caution for the grain cracking process.

Every Forgeworks Barley Cracker is tested. The cracked barley is assayed with 8" diameter & serial numbered Humboldt-USA sieves that comply with ASTM E11 and AASHTO M92. The results for each machine is recorded before leaving our shop. Our Barley Cracker is calibrated to specs that according to research, achieve the best efficiencies and flow.

<https://www.humboldtmg.com/8in-sieves.html>

Crack Testing with the 8" Humboldt Sieve Assay

Humboldt-USA 8" Standard Sieve

ASTM E11 / AASHTO M92

Sieve No.	Microns	Inches	Millimeters	Serial Number
14-Course	1400	0.0555	1.4	EE44614
30-Medium	600	0.0234	.60	EE53661
60-Fine	250	0.0098	.25	EE59139

Targeted Calibration for the Forgeworks Barley Cracker

	No. 14 Sieve-Course	No. 30 Sieve-Medium	No. 60 sieve-Fine	Pan-Flour
Trouble Free Brewing	70-85%	10-20%	Less than 10%	Less than 5%

The #14 sieve would retain husk pieces, but let the grits and flour fall through. The #30 sieve would retain coarse grits while the #60 would retain the fine grits. Flour would fall through all the sieves and land in the pan. All these particle sizes produced by the Barley Cracker's rollers, are combined and hydrated prior to entering your mash tun, and produce a grain bed for Trouble Free Brewing.



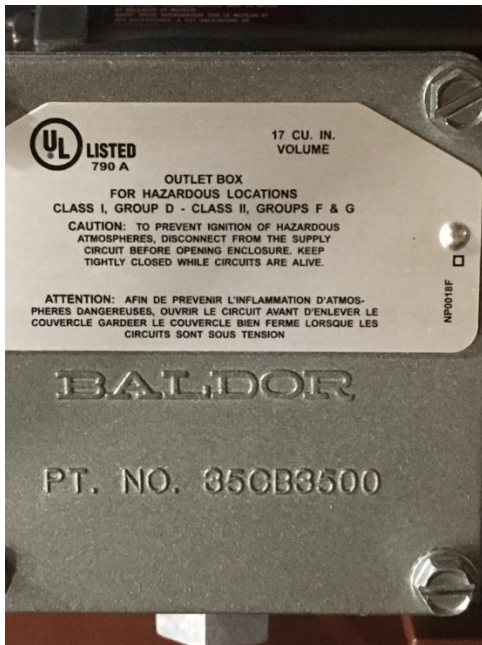

Lance Johnson
 Bennett Forgeworks, Inc.
 Office: 970-626-2100
 Cell: 970-316-5850
 Email: lance@forgework.com

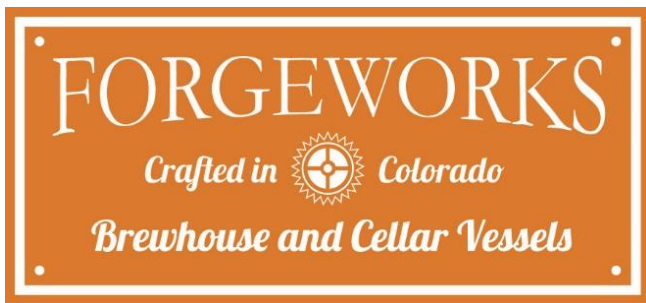

SECTION 9

Considerations for Laying out the Brewhouse-Orientation/Clocking

The Orientation Document you received has several pages associated with it, giving you details of how the Kettle would be "clocked" with the kettle on the left or right, in our standard configuration. By clocking we mean what position the manway, ports, other connections are in, relative to a clock, from a bird's eye view of the tanks, the front of each vessel being at 6:00, the back at 12:00.

Typically, you would want the Mash Tun to be on the side (Left or Right) that is closest to an exit that you plan to move the spent grain through. However, there are many other considerations that may deem this as less important.

What also needs to be taken into consideration is your auger or other grain conveyance to the mash tun. You may have to have the Mash Tun in a position where it is easy to route the grain conveyance tubing without obstacles or unnecessary turns.

Other considerations is the burner, and its position as we have it on the drawing. Will you be able to route Natural Gas to it in either position, Kettle Left or Right, and does the burner or exhaust port need to be shifted to account for obstacles (routing venting through the ceiling). For the Burner, figure a space of 16" x 20" Square.



Hot Liquor Tanks can be located anywhere, but typically are in line with the brewhouse. If you have a small area or many building features to work around, considering where the hot liquor tank will be placed, how does the clocking of its ports work with the space? Would hose connections be in the way of a walk-through path? In the way of any other operation that would be going on next to it, such as a keg washer, CIP Station, or other equipment?

Think about how staff will move through the space. Will the burner exhaust be too close to a doorway, or path of staff?

Heat exchangers can also be set anywhere, but the most ideal would be next to the Kettle. So consider the Left and Right orientation with heat exchanger in mind as well.

What can be very helpful is having your architect drop in our CAD file of the Brewhouse Footprint that is to scale. It can help everyone to begin to see things that we couldn't think of before.

OTHER CONSIDERATIONS

Proximity of port connections or Kettle & Mash Tun Venting to Hose Bibs, Wall Outlets, Support Beams or Pillars, Windows/Doorways

Visit lots of breweries, ask "why" questions about their layout and what they wish was different (things they hate).

Think about expansion plans

Can you easily get utilities to the optimal brewhouse location

How will you fit and access the brewhouse with other support equipment

- Totes / Tubs or Trash bins for grain out

- Fork Lift

- Portable pumps

If using soft hose connections, are they posing a hazard in a path that staff needs to walk?

Brewhouse/Warehouse flow

Maximum use of space

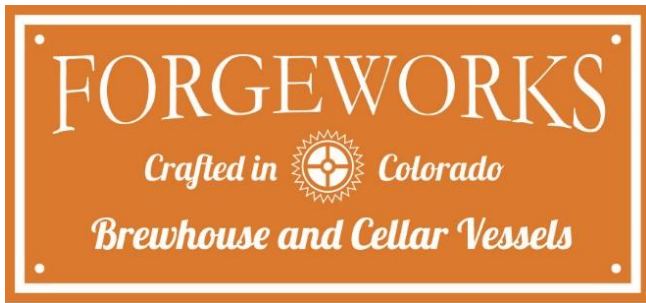

SECTION 10

Recommendations for Burner/Controller & Exhaust/Steam Flues

Revised 03-2020

The following information is intended to be recommendations and general guidelines, **not exact specifications and instructions**. The reason for this is because local building codes differ. We highly recommend that you determine that this information meets your local building codes before attempting to order any venting parts yourself. The information provided below should be adequate and thorough enough to serve as a starting point for a conversation and subsequent quote with a qualified engineer and/or HVAC Technician. The HVAC professional you select should be familiar with and adhere to NFPA 54, which is the National Fuel Gas Code. In terms of the venting of the exhaust and steam vents, it is best to consult an HVAC professional immediately upon receiving this document to avoid time delays in ordering specific venting products. Before ordering venting parts, it is important to completely evaluate how the venting will need to route through the ceiling/floors to the roof line. Also, you will need sufficient time to evaluate the HVAC expertise required and budget needed to complete the venting installation. Often, venting products and installation by a qualified HVAC professional can be quite unexpectedly costly, and time consuming. Ideally, your chosen HVAC company will have sufficient brewery expertise, and will have ordered and received the parts needed to complete the venting project by the time of your Forgeworks brewhouse arrives. Many required venting parts may not be readily available locally, and require special ordering with significant lead times.

The brew kettle requires the venting of steam and the most common method is to route the steam via a flue out the roof or side of the building. If this is not possible, a well designed condenser (also called a Heat Exchanger) must be attached to the Kettle.

If the Kettle is In-Direct fired by a gas power burner, an exhaust flue must be installed to vent the exhaust to the outside of the building. This is achieved with Class A double walled flue sections, and a Double Acting Gas Draft Regulator. Make-up air is also needed in the brewing area.

If the Brewhouse tanks are Steam Fired, you will likely be required to build an explosion proof boiler room. This room will also need steam venting and Make-up air. Contact your local licensing and inspection authority to learn about your area's requirements. In the design of the room, see that there is adequate space around the boiler equipment for ease of service and inspection.

Power Gas Burner

The burners that we specify for your Kettle or Hot Liquor Tank are Midco Economite Burners. Midco specifies its power burners operate on 6" to 14" of W.C. (Water Column). Our customers report optimal direct fired equipment performance with at least 10" of W.C., but optimally 12-14" supplying the burner. For specific information regarding wiring a thermostat, adjustments for your altitude, BTU output, and conversion to propane, follow the manufacturer's recommended adjustments in the appropriate manufacturer supplied manual, so as not to exceed the temperatures in the flu that your exhaust venting choice is rated for.

If your burner arrived without an instruction manual included, a PDF of your specific burner manual is available from Forgeworks.

NOTE: Be sure to establish what gas pressure is achievable into your building before installing and firing the burner. A fired burner is not returnable for a model exchange, unless for warranty purposes.

HIGHLY RECOMMENDED: It is suggested by Midco International to have your HVAC Professional install a In-Line Gas Pressure Regulator to make sure the Water Column pressure does not exceed 14" and compromise the burner. Maxitrol Gas Pressure Regulators are a common and trusted brand:

<https://www.maxitrol.com/>

Midco Economite Burner models are (Links will include Product Information, Installation and Parts List, Service Bulletins & Warranty Policy:

-3.5-7bbl Kettles and Hot Liquor Tanks: Economite EC200, 200,000BTU

http://www.midcointernational.com/products/economite_ec/index.htm

-10bbl Kettles and Hot Liquor Tanks: Economite EC300, 300,000BTU

http://www.midcointernational.com/products/economite_ec/index.htm

-Alternative Burner Option for 10bbl Kettles or Hot Liquor Tanks: Economoite RE4400DS HTD, 400,000BTU

http://www.midcointernational.com/products/economite_re4000/re4400htd/

-15bbl Kettles & 15 & 20bbl Hot Liquor Tanks: RE4700, 700,000BTU's

http://www.midcointernational.com/products/economite_re4000/re4700ba/

Other Burner Options that may have been purchased via Forgeworks:

-Midco Economite RE4400DS, Modulating Burner (Natural Gas Only)

http://www.midcointernational.com/products/economite_re4000/re4400ds/

-If the burner is for a Hot Liquor Tank, the burner may have been down sized following a discussion between the Forgeworks Sales Representative or Engineer, and the Brewery Customer based on need/usage.



Because we are not licensed HVAC professionals, we are limited in providing information for the installation and adjustment of the burner. The staff at Midco are very helpful, but you will want them to connect with your HVAC professional. Because of the nature of this equipment, they too are limited with the information they can share about installation and tuning of the burner with a non-licensed HVAC professional.

Midco International

<http://www.midcointernational.com/>

866-705-0514

For safety, A cut off switch for the burner needs to be installed in proximity to the working area around kettle in the case of a boil over. Also, the cut off switch doubles as a protection for accidentally dry firing the kettle.

Burner Installation:

Tank Placement:

For placement of the Kettle or Hot Liquor Tank in your brewery to allow adequate clearance for the burner, figure a 16" width x 20" length area. The burner mounts to the Kettle or Hot Liquor Tank via the burner's universal flange, married up to (4) .25" bolts that are fixed on the vessel around the 4.125" burner port. The .25" nuts are supplied, and come threaded on the bolts over a washer.

4-Match the gasket to the flange, and remove the “punched” material from the gasket for the appropriate hole locations that correspond with the burner port bolt inserts (with the flat section at the bottom, the positions are at 12 o'clock, 3 o'clock, 6 o'clock, and 9:00 o'clock).

5-Using the (4) flange bolts & washers, attach the flange and insulating gasket to the to the tank, with the insulating gasket between the flange and the tank. Evenly tighten each bolt in a rotating pattern, much like changing a car tire. Note: -The flange is flat, and as you tighten up the bolts it will conform the shape of the tank.

6-Making sure the flange bolts are loosened, slide the burner snout (stainless section) through the flange. It may take some effort to wiggle the snout into the correct position. If you are having trouble getting the snout through the flange, try loosening the flange bolts some more, until the snout is able be inserted.

7-By looking through the access panel, determine that the burner is inserted so that it is flush or just slightly proud of the inside of the insulation. In other words, insert the burner snout through the shell, pass through the 1-1/2” of insulation and stop when the snout of the burner is flush to the ID of the insulation or up to ½” proud of it. Just make sure the insulation does not get caught on the snout of the burner, or that there is any insulation directly or in front of the burner in any way.

8-Via the access panel, examine the insulation around the burner snout. Press on the insulation all around the snout, and double check the position of the snout.

9-When the position of the snout is determined to be correct, first tighten the flange bolts in a rotating fashion, then secure burner in place with the (3) flange set screws (1/8” allen wrench). Evenly tighten in a rotating pattern.

10-Check the insulation around the snout again, then reattach access panel door.



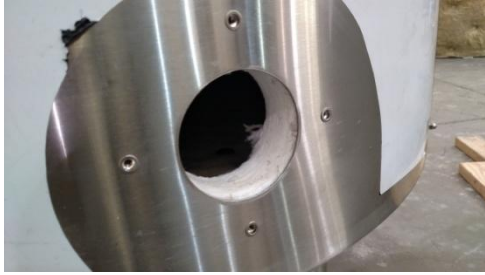



Burner Installation Procedure for the RE4700

The steps for the RE4700 are similar to the EC200&300 except that the flange comes pre-installed onto the snout, and is not removable. Many of the pictures above in the installation steps for the EC200 & EC300, will apply to the installation of the RE4700.

Tools Needed: Small Crescent Wrench or 7/16 wrench/socket, 1/8" allen wrench

1-Remove the access panel door (via (6) acorn nuts, 7/16) to be able to see that all insulation is in good shape around the burner snout after installation, and that no insulation is blocking the burner. Note the orientation of the panel door, and reinstall in same position to make sure the holes will line up exactly with the bolts.

2-Remove the (4) flange bolts & washers from the burner port of the tank.

3-On the burner, loosen the (3) set screws (1/8" allen wrench required) on the flange so that it can move around on the pipe, behind the stainless cuff.

4-Locate the white insulation gasket (pictured above), and remove the punched out material to match the (4) hole patter of the burner port (with the flat section at the bottom, the positions are at 12 o'clock, 3 o'clock, 6 o'clock, and 9:00 o'clock).

5-Place the insulation gasket over the burner snout and match up to the flange.

6-This step will require a helper for best results. Insert the burner snout through the burner port, and while holding the burner in position, have your helper look through the access panel to see that the burner snout is in the correct position (pictured above). When in position, place the (4) flange bolt & washers into the bolt inserts of the burner port. Tighten in a rotating pattern, but do not tighten completely. Note: the flange is flat, and as you tighten up the bolts, it will conform the shape of the tank.

7-Double check the position of the burner snout. Follow steps 7-10 above (in the EC200 & EC300 instructions)



Fire Chamber Insulation Specifications: The Indirect Fire Chamber is insulated with HarbisonWalker International's refractory product; Inswool HP 8#, a 2300°F/ 1300°C Rated, Alumina Silica Ceramic Fiber Blanket (1.5" Thickness).

Product Safety Data Sheet: <https://thinkhwi.com/products/inswool-hp-blanket-8/>

HarbisonWalker International Contact Information:

<https://thinkhwi.com/>

412-375-6600

Technical Support:

412-375-6756

Email: technical-marketing@thinkhwi.com

Gas Connection: The Gas connection on the burner is .75 NPT.

NOTE: When testing the burner for any needed adjustments, be sure to fill the Kettle or Hot Liquor Tank with at least 6" - 8" of water.

Burner Controller & Required Parts for Thermowell

Many of our customer have chosen the Johnson A421 to control the burner. The Thermowells on our vessels are .5" FNPT, 7" Deep.

Johnson A421 Controller and Thermoprobe Link PDF:

http://www.johnsoncontrols.com/-/media/jci/be/united-states/refrigeration/commercial-refrigeration/files/be_cat_penn_sselectronictempcontrols.pdf

Controller and 7" Thermowell Parts



-Qty 1 – A421ABC-02C Johnson Controls Temp Control. Suggested Supplier: HVAC Parts Warehouse
<https://www.hvacpw.com/johnson-controls-a421abg-02c-electronic-temperature-control-with-pre-wired-power-cords.html>

Or

https://www.supplyhouse.com/sh/control/product/~product_id=A421ABC-02C

-Qty 1 – ½” NPT to ¼” Tube adapter, Grade 316 Stainless Male. Suggested Supplier: MSC Direct. Brand is Ham-Let. Mfg. Part #3001998, MSC Part #86760584

<https://www.mscdirect.com/product/details/86760584>

Alternative Supplier for the above fitting:

http://www.brewhardware.com/product_p/comp14tx12mnpt.htm

The above fitting is used to secure the thermoprobe in place. Install thermoprobe with Thermal Conductive Paste. Take caution not to wrench on the fitting too hard, or it may collapse the wiring.

-Qty 1 – Thermal Conductive Paste. We have used SKU Number 107408 from Supplyhouse.com before with good results.

<http://www.supplyhouse.com/Honeywell-107408-Heat-Conductive-Compound-4-ounces>

ELECTRIC FIRED HOT LIQUOR TANK

In the case of Electric Fired Kettles or Hot Liquor Tanks, determine your particular scenario of usage, and verify with your Electrician the required electrical power capacity, and type of immersion heater(s) needed.

Our customers have been successful sourcing Immersion Heater Elements from McMaster-Carr, however, there are less expensive alternatives. We recommend you shop.
630-833-0300

<https://www.mcmaster.com/>

Immersion Heaters Page

<https://www.mcmaster.com/#immersion-heaters/=122ss2k>

On this page, click on “more” under “About Immersion Heaters” to see charted information about minimum wattage required to Heat Water

Power Requirements for Electric Immersion Heaters

In General, any time you are taking your Liquor from tap temperature to strike temp or boil, you will need multiple immersion elements, and 3-Phase 480 Volt Power.

Example:

7bbl Hot Liquor Tank, at approximately 324 gallons

10bbl Hot Liquor Tank, at approximately 400 gallons

15bbl Hot Liquor Tank, at approximately 515 gallons

	Minimum Wattage Required to Heat Water (6-Hr. Warm-Up Time)						
Gallons	10° F Temp Rise	30° F Temp Rise	50° F Temp Rise	70° F Temp Rise	90° F Temp Rise	110° F Temp Rise	130° F Temp Rise
200	900	2700	4500	6300	8100	9900	11600
400	1800	5400	9000	12500	16100	19700	23300

Hot Liquor Tank Scenarios (3)

-Supplemental hot water from a Hot Water on Demand System (Tankless Water Heaters)

<https://www.rinnai.us/>

Have your Architect or HVAC Professional evaluate the Rinnai Model C199iN. Several of these units can be strung together, and retail for approximately \$2200. <https://www.rinnai.us/commercial-water-heating/catalog/tankless/hybrid/c199>

Whether you are single or double batching, this scenario assumes you are supplementing or filling your Hot Liquor Tank via a Hot Water on Demand System. To maintain or raise the temperature slightly for a single batch, this could be achieved with (1) Immersion Element, in which Single Phase Power may be acceptable, but 3-Phase, 240 Volt Power may be required. If double batching, and starting with heating your Liquor in your kettle, transferring to the Hot Liquor Tank, and supplementing with water from your On-Demand system, you may still be ok with (1) immersion heater. Make sure the Hot Water on Demand system you buy is designed to keep up with the scenario you will most likely be utilizing.

-Single Batch Brewing

This assumes you are heating your Liquor in your Direct Fire Kettle to just above strike temperature, then transferring to the Hot Liquor Tank. A single electric element is sufficient in this case to raise the temperature

up, if needed, or maintain your target strike temperature. Single Phase Power may be acceptable, but 3-Phase, 240 Volt Power may be required.

-Double Batch Brewing

Double batching has two methods in which to have enough Liquor for two brews with close to a seamless transition between them. One option is to start the previous day with heating your Liquor in your kettle, then transferring to the Hot Liquor Tank. Tap water is added to the HLT to make up the difference needed for a double brew day. One immersion element could do the job overnight to bring all the Liquor up to strike temperature overnight. Two elements may be required, depending on the size of your tank.

Option two is to fill the Hot Liquor Tank with tap water for the next day's double brew. Then using multiple (3-4) immersion elements, you heat the water over night. The power requirement for this scenario would be 3-Phase, 480 Volts.

NOTE: Whatever your scenario of usage, it is essential to keep at least (1) Electric Immersion Element on hand, as they do wear out. Do not dry fire, make sure each element is completely submerged in liquid before firing. In the case of a dry fire, the element will fail and need to be replaced.

VENTING

In-Direct Fire Exhaust Venting

At a minimum, the venting from the Kettle or Hot Liquor Tank shall be comprised of insulated, Stainless Steel lined, Stainless Steel Outer, Class A chimney parts. A minimum of 2" of clearance must be maintained from walls and combustibles. Any needed wall supports or other supports by the manufacturer of your venting choice, provide at least 2" of clearance. The first two parts of the venting, the exhaust port adaptor and the Tee, will require 12" of width and 18.5" (for 3.5bbl-10bbl, and 16" by 20.5" for 15bbl) of length for appropriate clearance from walls and other obstacles (picture a 12" by 18.5", or 16" by 20.5" for 15bbl, rectangle jetting out from the kettle, on center from the location of the exhaust port).



DIMENSIONS AND CLEARANCE REQUIREMENTS FOR DIRECT FIRE BURNERS & EXHAUST

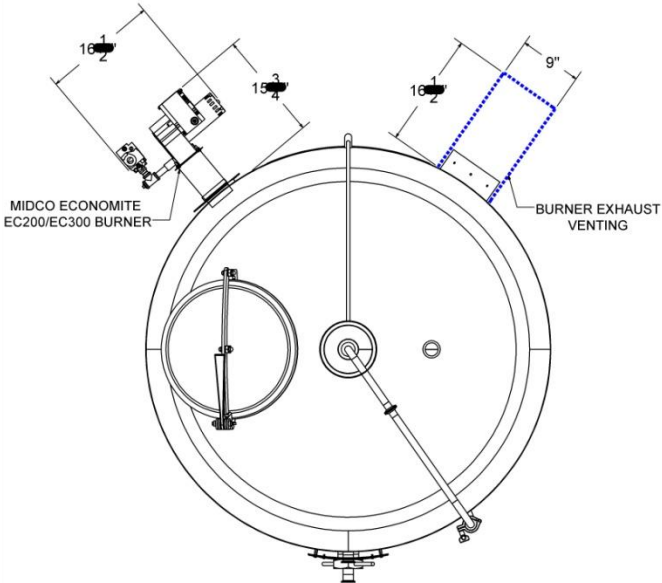

3.5-10 BBL KETTLE, DIRECT FIRE HLT

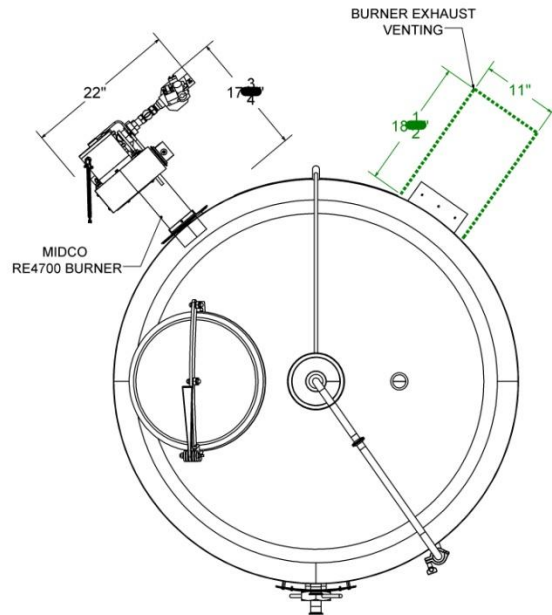

15+ BBL KETTLE, DIRECT FIRE HLT

CURRENT REVISION: A		TOLERANCE INFORMATION: X.X ± 0.125 X.XX ± 0.060 X.XXX ± 0.020 X.XXXX ± 0.010		MATERIAL: 304 STAINLESS STEEL		SERIAL NUMBER	FINISH: 316	VOLUME: 467 GAL	WEIGHT: 853.62 Lb
REV#	DESCRIPTION	DATE	FRACTURE: A2/16	3RD ANGLE	ASM / PART / WELDMENT DESCRIPTION:				
			WELDING INFORMATION: WPS: WPS-304L-316		DIRECT FIRE KETTLE, INSULATED				
CUSTOMER NAME / COMPANY			CONFIGURATION		10BBL-KI ASM	FILENAME / PART NUMBER			SHEET 1 of 1

The Kettle or Hot Liquor Tank Exhaust port sizes are as follows:

3.5 - 10bbl: 8ID Collar"

15bbl & 20bbl: 12ID Collar"



Exhaust Chimney Parts

Many of our brewery customers have had success with Selkirk SuperVent, Selkirk MetalBest Ultra-Temp and Field Controls (draft control) products to equip the venting for both exhaust and steam venting. Your HVAC Professional may recommend a different brand, as well as different required parts. Mix and match use of different brands/models of chimney, even from the same manufacturer, may not interchangeable. Keep the brand and model of parts the same for the entire system. The brand Selkirk is just a suggestion. Here is a few more companies that offer quality venting products for your comparisons:

[Ameri-Vent](#)

[Dura-Vent](#)

[Metal-Fab](#)

In the case of the Selkirk SuperVent products, many of the parts you will need are commonly available in store or on-line at Lowe's or Menards. For the purposes of this document, we will detail the basic required parts, from the Exhaust exit to the wall exit or ceiling, with the brands suggested above.

<https://www.lowes.com/pl/Chimney-pipe-Chimney-pipe-accessories-Fireplaces-stoves-Heating-cooling/4294506739>

<https://www.menards.com/main/heating-cooling/venting/insulated-double-wall-stove-venting/c-6894.htm>

Selkirk MetalBest Ultra-Temp products are available at woodstovepro.com

For any consultation about these products, Contact Selkirk at 800-992-8368, sales@selkirkcinc.com.
<http://selkirkcorp.com/>

Selkirk makes the brands SuperVent (304SS inside, 430SS Outside), Ultra-Temp (304SS inside, 430SS Outside), and SuperPro (303SS inside and 304SS outside).

An engineer may decide to reduce the pipe size after the Draft Control, at their discretion. The 12" version of Venting for the 15 & 20bbl Kettle or Hot Liquor Tank are quite expensive. You may consider consulting your HVAC professional about reducing the Class A pipe diameter above the Draft Control.

Below is a general list of parts needed to vent the exhaust up to the ceiling. Consult your HVAC Professional on the required wall supports, and any additional parts or kits needed for various wall, ceiling, attic, and roof top configurations.

Initial Required Parts for Exhaust Vent (to the ceiling, or wall exit)

Below are the images of the parts you will need for the initial connections:

- (1) Adapter to connect from the exhaust port to a Tee
- (1) Tee with Plug used for initial exit from exhaust port, connects to adapter
- (1) Tee (without plug) for use with the draft control
- (1) Draft Control, inserted into the Tee

-Various quantities of straight 6", 9", 12", 24", or 36" Class A Piping Sections, with or without any needed 15° or 30° Elbow sections to route around ceiling obstacles, etc.

-Section Locking Bands

-Any needed Wall Supports (usually for use with Tees), and Wall Bands (secures piping to wall)



Generally, the fewer bends in the exhaust flue the better. The initial configuration of the exhaust venting is as follows: the flue exits the Kettle or Hot Liquor Tank via the adapter, turns 90° via a Tee & Plug, connecting to one straight section of 36" or 48" (if available in your selected brand) Class A chimney piping, connecting to a Tee (without plug) for the Draft Control. Then, ideally the flue continues vertical, on up and through the roof. If turns are needed, 15° and 30° Kits are available. Because of the many different scenarios of wall exits or ceiling exits angles, piping through attics, and various roof line possibilities, for the purposes of this document, we do not detail any of those parts.

Vertical Support for the weight of the venting is required. Support under the initial Tee, and or via use of a Wall Support at the initial Tee or Tee with the Draft Control is recommended. Vertical stabilization for the chimney

is also required. Check the manufacturers specifications for information on various types of supports, and required support intervals for your specific piping. Use of Unistrut products can be useful in weight support and bracing. This product can be found at Lowe's or Menards. <http://www.unistrut.us/index.php>

8" Version SuperVent Part Codes for Exhaust Vent

Selkirk SuperVent Class A (check Lowe's or Menards. Links are above)

PART	CODE	Lowest Price
Adapter	JSC8SE	\$27
Tee with Plug	JSC8SITS	\$110
Plug only	J811TPI	\$46
6" straight piping section	JSC8SA6	\$32
12" straight piping section	JSC8SA1	\$57
18" straight piping section	JSC8SA18	\$69
24" straight piping section	JSC8SA2	\$80
36" straight piping section	JSC8SA3	\$110
15° Elbow Kit	JSC8SEK	\$160
30° Elbow Kit	JSC8SE3K	\$223
Wall Band	JSC8WBM	\$16
Wall Support (for use with Tee)	JSC8AWS	\$48
Locking Band	JSC8SLBM	\$8
Field Control Draft Control	8-MG1	\$83

NOTE: There are Adjustable straight sections available. These sections must be used above a fixed length section, and not immediately above a support, tee or elbow.

Selkirk SuperVent Catalog & Installation Instructions

https://hw.menardc.com/main/items/media/SELKI001/Prod_Tech_Spec/superventproducttechspecs.pdf

12" Version Part Codes for Exhaust Vent

Selkirk MetalBest Ultra-Temp Class A

<https://woodstovepro.com/chimney-pipe-venting-pipe/wood-all-fuel-piping/>

PART	Product No. / Part No.	Lowest Found Price

Adapter	212240 / 12S-CPA	\$67
Tee with Plug	212100 / 12S-IT	\$681
Plug/Cap only	212102 / 12S-IP	\$88
6" straight piping section	212006U / 12U-6	\$187
9" straight piping section	212009U / 12U-9	\$212
12" straight piping section	212012U / 12U-12	\$196
18" straight piping section	212018U / 12U-18	\$250
24" straight piping section	212024U / 12U-24	\$260
36" straight piping section	212036U / 12U-36	\$488
15° Elbow Kit	212206 / 12S-EL15KIT	\$504
30° Elbow Kit	212211 / 12S-EL30KIT	\$598
Wall Band	212520 / 12S-WB	\$16
Wall Support (for use with tee)	212430 / 12S-WSK	\$58
Locking Band	212450 / 12S-LB	\$20
Field Control Draft Control	12" M+MG1	\$180

NOTE: There are Adjustable straight sections available. These sections must be used above a fixed length section, and not immediately above a support, tee or elbow.

Selkirk MetalBest Ultra-Temp Product Catalog

<http://selkirkcorp.com/sitecore/content/global-configuration/selkirk/products/chimney/ultra-temp>

Draft Control for Exhaust Vent

A draft control should be used in the exhaust stack to cool the gases and reduce the velocity of the exhaust charge. Typically, it is installed after a 36"- 48" single section of pipe above the initial Tee (90° transition to vertical) from the exhaust port on the side of the Kettle or Hot Liquor Tank.

Many of our customers have had success with a draft control by Field Controls, LLC.

<http://www.fieldcontrols.com/>

252-522-3031

Field Controls Draft Controls can be found at SupplyHouse.com

<https://www.supplyhouse.com/>

800-757-4774

Parts

Draft Control Type MG-1 for the Selkirk SuperVent 8" Tee
8" MG-1

<https://www.supplyhouse.com/Field-Controls-8-MG1-8-Double-Acting-Gas-Draft-Regulator>

Draft Control Type M+MG2 for the Selkirk MetalBest Ultra-Temp 12" Tee
12" M+MG-2

<https://www.supplyhouse.com/Field-Controls-12M-MG2-12-Draft-Regulator-for-Oil-Gas-Wood-and-Coal>

Field Controls Draft Control links:

http://www.fieldcontrols.com/draft-control-1?page_id=95

<http://www.fieldcontrols.com/filebin/pdfs/4129DraftControlGuide.pdf>

<http://www.fieldcontrols.com/draft-1>



It is essential that your HVAC installer send a temperature probe into the exhaust vent both below and above the draft control and verify that the exhaust temperature is not exceeding the design specs of your chosen vent products. The burner can be tuned to adjust the exhaust temperature if necessary. The temperature of the flue gasses where they exit the kettle should be just under 1000° F. and the temperature above the atmospheric damper should run around 500° F., but in either case shall not exceed the continuous temperature rating of your selected vent products.



Steam Vent

For the Steam Vent on your Kettle or Hot Liquor Tank, the sizes are as follows:

- 3.5 & 5bbl: 6"
- 7 & 10bbl: 8"
- 15 & 20bbl: 10"

This vent is single wall. The first section of vent needs to be Stainless Steel. The remainder can be aluminum. Be sure that your steam vent pipe has a crimped end on it so that it will fit inside the collar on the top of the Kettle or Hot Liquor Tank; if not it will allow fluid to leak through the joint and make a mess on the outside of

the kettle. Use only stainless-steel screws attachment of sections, hood, etc. Do not use galvanized piping, the caustics and other chemicals used in the cleaning of the kettle will degrade galvanized, and introduce rust into the Kettle or Hot Liquor Tank. NOTE: Both the exhaust and the steam vent need their own exit route out of the building. These two systems cannot be merged.

Installation of the Forgeworks Slide Gate for the Steam Stack

If you ordered a Forgeworks Slide Gate for your steam stack, these are inserted at the Kettle's Steam vent exit, fitting over the Kettle's vent connection pipe, and feature a slot on the top side of the slide gate to insert your steam venting. No screws or clamps are required to install.

Particularly lengthy runs of the steam vent can cause draw issues. Also, very cold outside temperatures during the Winter season can contribute to draw issues. In these cases, it may be necessary to incorporate a non-corrosive in-line fan (aka duct booster) that can be switched on and off to establish a draw. If your venting is straight (no curves), evaluate installing this in-line fan via a "Y" (45° branch) section, thus entering the straight section at an angle. This avoids having the fan in a position where condensation from the fan would drip straight down the pipe, back into your kettle (not flowing down the venting wall, which would be collected by the condensation ring on the kettle). If a "Y" (45° branch) is not achievable, or if you have a bend/jog in the piping routing, place the inline fan on the "jog" section, so that condensation will run down the wall of the piping.

Consult your engineer and/or HVAC Professional! Ask other local breweries who they have used. In addition to potential equipment performance issues, there are also serious safety hazards if the burner and venting is installed incorrectly, including fire and carbon monoxide poisoning.

Other Venting Product Resources

<http://www.lindemannchimneysupply.com/>

<https://www.ventingpipe.com/duravent-vent-pipe/c22>

https://www.ventingpipe.com/metalbest-class-a-chimney-pipe/c1035?soure=gg_!165166862!a36579221927!k%20selkirk%20%20lass%20%20a!mb!p1o1!d!ng!f%3Fpage%3Dbrowse%3Acategory&cvosrc=ppc.google.%2Bselkirk%20%2Bclass%20%2Ba&cvo_cid=165166862&cvo_crid=96051171902&matchtype=b&cvo_adgroup=36579221927&qclid=EAlaIQobChMIrpPQg43x1wIVBsZkCh35xQdCEAMYASAAEqIAZfD_BwE

<https://woodstovepro.com/chimney-pipe-venting-pipe/wood-all-fuel-piping/>

Forgeworks Contacts:

Lance Johnson, Sales & Marketing

lance@forgework.com

Cell 970-316-5850

Will Brumas, Product Engineer

will@forgework.com

**Fabrication Office 970-890-1050, Monday-Thursday 6:30a-5p
Cell 703-399-9819**

Tom Bennett, President

tom@forgework.com

Cell 970-729-0516

Bennett Forgeworks, Inc

P.O. Box 830 / 669 N. Cora St.

Ridgway, CO 81432

Administration Office 970-626-2100, Monday-Thursday 6:30a-5p

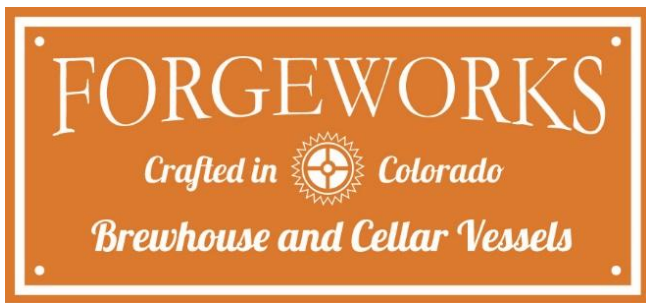

SECTION 11

Buyer's Responsibility Checklist

- ✓ Prior to approval of final drawings, making sure the equipment purchased fits in the building via intended doorways, and workspace? Consider ceiling height, width, obstructions in the workspace.
- ✓ Determining that the ceiling height is adequate for the purchased vessel to be righted into place from a horizontal position, should it need to be manipulated that when taking delivery of tanks.
- ✓ Equipping all tanks with your preference of brands and types of Valves, Fittings & Hoses, unless purchased via specific package.
- ✓ All required permits, code requirements, and facility engineering
- ✓ Confirmation that facility floor structure has been deemed sound by an engineer for operating weight of supplied equipment
- ✓ Contracting of, and direct payment for shipping. Shipping will be from the Bennett Forgeworks fabrication facility in Ridgway, CO. We will provide all dimensions and weight for your quote shopping, and will provide one quote from Freight Quote. Pick up is available 7am-4pm Monday -Thursday. Local pick up by customer will incur additional applicable taxes.
- ✓ Receiving, inspecting for damages during shipping, offloading, rigging and placement of tanks
- ✓ Drilling of Anchors into concrete (if applicable for seismic code regulations) to secure feet of vessels
- ✓ Water delivery lines to tanks, including a hot/cold water mixing fixture. It is recommended that your main water line be 60psi at 25-30 gpm.
- ✓ CO2 Runs
- ✓ Water filtration equipment
- ✓ Direct Purchase of any required Electric Immersion Elements, for Electric Kettles or Hot Liquor Tanks
- ✓ All Plumbing and Drainage from each vessel, unless process piped by Forgeworks
- ✓ Waste Water treatment
- ✓ Hard wiring of a purchased Forgeworks Barley Cracker. Purchase of grist conveyance system and installation.
- ✓ Hanging /Mounting of Grist Hoppers (if applicable)
- ✓ Electrical wiring to all equipment
- ✓ Boiler selection, installation, start up and commissioning
- ✓ Steam system piping, required fittings, and installation if applicable
- ✓ Direct Fire Burner installation, gas hook up, start up and calibration, installation of controls
- ✓ Natural Gas/Propane Piping, verify that you will have delivery of 12-14" of Water Column Pressure
- ✓ HVAC ducting/venting (we recommend you begin lining out this project prior to receiving the tanks, sourcing venting parts to be ordered)
- ✓ Purchase and installation of all Direct Fire Burner Exhaust Chimney parts
- ✓ Purchase of Glycol Chiller, installation, and commissioning Glycol for cooling system (Cellaring Vessels)
- ✓ Glycol system piping and controls from refrigeration unit to equipment
- ✓ Cleaning and Passivation of your new Forgeworks vessels prior to operational usage
- ✓ Commissioning of the equipment
- ✓ Installation and use of CO2 Monitors
- ✓ If purchase of a pressure vessel (Fermenter, Bright, Bright/Serving Tank), you accept responsibility to ONLY USE a Pressure Relief Valve with MAX of 14.9 PSI with Forgeworks provided equipment.

- ✓ Pressure Relief Valve inspection and cleaning after each brew/batch. MAX 14.9psi
- ✓ Living the dream
- ✓ Solving thirst issues by providing tasty beer/wine/spirits/refreshments